

**CURRENT SWITCHES
ADJUSTABLE SET POINT**

ESOL.. ESLT..

These devices are powered by induction from the monitored AC conductor which passes through the hole/core. They sense the current flow and can thereby monitor the operation/failure of fans, pumps, motors, etc. The Normally Open triac switch closes when the current flow exceeds the set point. The switch point is adjustable via a multi turn pot.



Hysteresis: <2% Full scale max
Enclosure Flammability: UL94-V0
Operating Temperature: 0 to 70°C
Response Time: <200mS

Type	Description	Switch Rating Max	Input Frequency Range	Leakage Current	Set Point	Conductor Current Input Selectable Range
ESOL-325NS	Solid Core	250VAC 1A	10 - 400Hz	<1mA	Adj	1.25-6, 6-40, 40-200A
ESLT-325NS	Split Core	250VAC 1A	10 - 400Hz	<1mA	Adj	1.6-6, 6-40, 40-200A

On State Volt Drop - amount of voltage which drops through the switch contacts when they are closed.

Leakage Current - current leaked across the switch contacts when they are open.

Both factors are very small and generally insignificant for most applications.

DIMENSIONS:

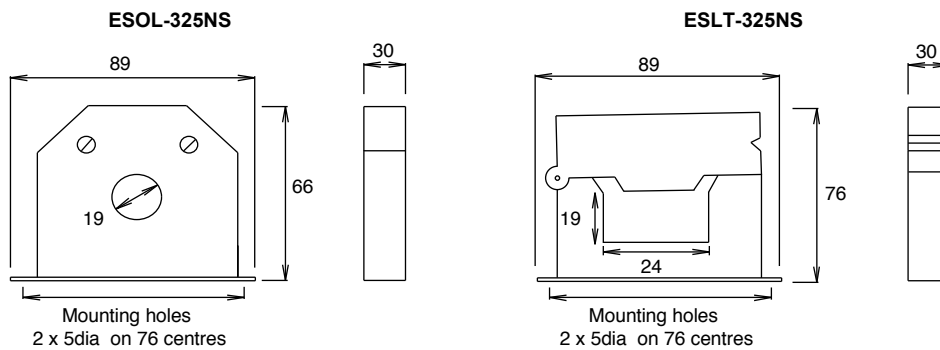

WIRING:

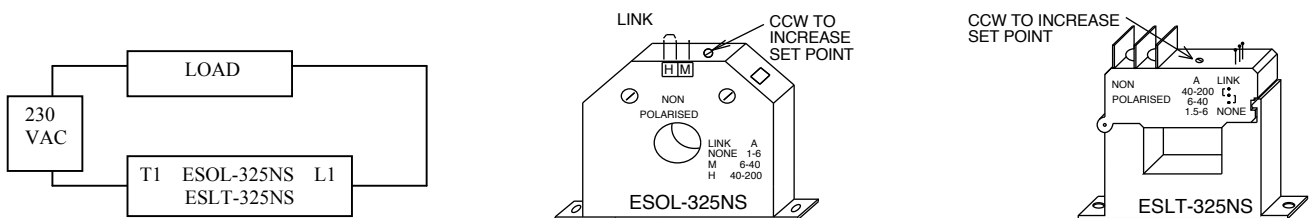

INSTALLATION: Ensure core is clean as dirt/foreign particles may prevent correct operation. If the conductor current is too low ie 0.5A, loop through the sensor more than once, ie 3 loops = 1.5A, this also divides the maximum range by 3. If the conductor wire is too large, or the current too high it can be wired to the primary side of a current transformer, the secondary side then passes through the hole/core.

Do NOT exceed the voltage or current ratings as this will cause damage to the device. Pass only the live conductor/wire through the core. Ensure link/jumper is in the correct position before switching the power on. The switch contacts are non-polarised.

The solid state switch contacts can only be checked for operation when the switch circuit power is applied.

Under current indication : Belt, fan or pump failure : For normal running the current should be above the set point & the switch contact closed. If the belt is broken, fan or pump stopped or the electrical supply fails the switch contact will open.

Over current indication : Locked rotor. For normal running the current should be below the setpoint and the switch contact should be open. When current exceeds the set point the switch contact closes providing indication of current flows above the normal full load amps.

SET POINT ADJUSTMENT: Factory set to minimum (adjustment fully clockwise) To increase set point, turn monitored load on, (the NO contacts will close) turn the adjustment counter-clockwise until the switch contacts open as indicated by the status LED or a voltmeter connected to the switch. Then turn adjustment clockwise until the LED comes back on or voltmeter is seen indicating contacts closed. LED is not fitted on all types. The adjustment should then be turned slightly clockwise past this point to ensure current fluctuations do not cause false conditions.