

WIND SPEED AND DIRECTION SENSORS

EWS..

<p>These products are suitable for measuring wind speed or wind speed and direction in such applications as automatic window closure in high wind conditions or general monitoring applications. They can be operated with zero power and are suitable for wiring into BMS systems.</p>	 <p>EWS-D-2..</p>	<p>Electrical connection 3m cable. Max Ambient -20/+70°C A mounting bracket is provided suitable for mounting onto a horizontal/vertical pole - Max pole diameter 50mm. Flammability - Anodised aluminium assembly with plastic cups and vane.</p>
---	--	--

Type	Application	Range	Output	Switch Rating	Max Current	Start Speed	Accuracy	Protection
EWS-4	Wind Speed	0-90m/s	switch contact 1 pulse/1.493m	0-100 VDC Max 0-50W DC resistive	0.5A 0-24VDC	0.5m/s from zero wind speed	2%	IP65
EWS-D-2	Wind Speed & Direction	0-90m/s 0-360°	switch contact 1 pulse/1.493m	0-100 VDC Max 0-50W DC resistive 0-1 kΩ pot 0-357° endless travel	0.5A 0-24VDC	0.5m/s from zero wind speed 3° headband at North	2%	IP65

SPECIAL ORDER ONLY

Speed measurement - magnetic reed switch producing one contact closure per rotation, which is equivalent to 1.493m travel. Counting this over a time period produces a rate in m/s.
10000 revolutions per hour = 14930 metres per hour = 14.93 Km/h = 4.148 m/s m/s x 3.6 = km/h.

DIMENSIONS:

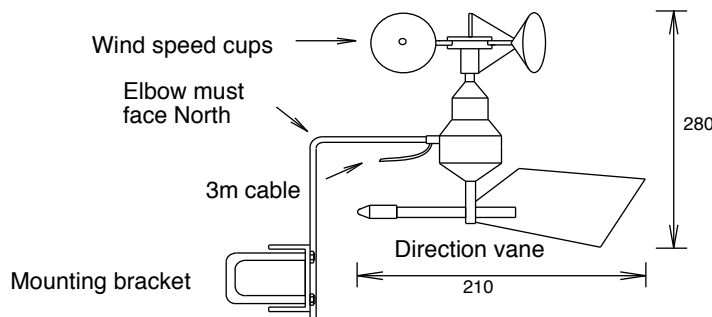

WIRING :

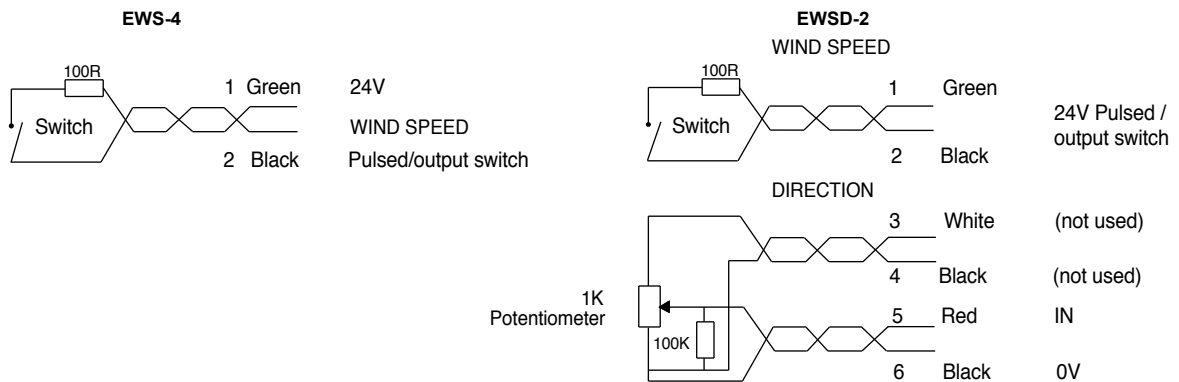

The 3m cable can be extended using screened 7/0.2mm wire equivalent to Belden 9503. The screen is not connected in the sensor and should be earthed at the controller end. Keep away from power cables/units which may cause interference.

INSTALLATION:

The unit should be mounted on a pole at a height of about 2m. Situate the unit in a clear site which is most representative of the area to be monitored. Avoid extremes ie hilltops which may indicate increased wind speeds, or valleys and in close proximity to trees and buildings which may indicate decreased wind speeds due to shielding. Several sensor heads can be installed to give spatial coverage and thus achieving more precise results. Ensure the elbow points NORTH using a compass or gently rotate the vane until 0 or 357 is indicated on a suitable measuring instrument, as this will represent North. Fix and tighten the bracket at this position.