

**B.M.S RESISTANCE INPUT MODULE
135/1000Ω IN 0-10VDC OUT**

ERIM

These units convert 0-135 ohm or 0-1000 ohm input to a 0-10vdc output.



Multi-turn pot to adjust output.
LED indication
Max ambient -10 /+50°C
Din-Rail mounting
Flammability = UL94-V0

Type	Supply ±10%	Input Adjustable	Output	Consumption	Mounting	Protection
ERIM 135R	24VAC/DC	0-135Ω	0-10VDC	20mA	Din Rail	IP00
ERIM 1K	24VAC/DC	0-1000Ω	0-10VDC	20mA	Din Rail	IP00

DIMENSIONS:

ERIM 135R/1K

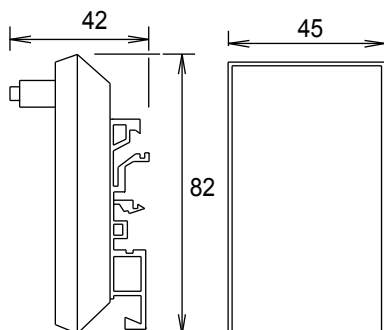

WIRING:

ERIM 135R/1K

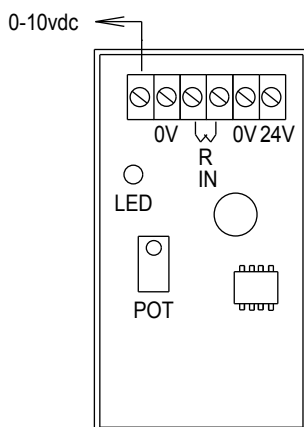

INSTALLATION:

Terminals 0.5-2.5mm² rising clamps

Min sensor / control signal cable size 7/0.2mm

Screened cable is recommended

The screen should be earthed at controller end only

Keep sensor/control signal wires away from power cables/units which may cause interference.

**B.M.S INPUT - OUTPUT MODULES
ANALOGUE RESCALING VDC / mA**

ARM

<p>■ This unit can be used to convert / rescale current or voltage signals:</p> <p>VDC input converted to mA output. mA input converted to VDC output. mA or VDC input to mA or VDC reversed output. Enlarging or reducing signals.</p> <p>Adjustments are made using the potentiometers.</p>		<p>Input Impedence: 1MΩ Voltage 250Ω Current</p> <p>Consumption: 200mA maximum</p> <p>Output current: 44mA maximum</p> <p>LED Power Indicator</p> <p>Common Applications :</p> <p>4-20mA in to 0-10Vdc out 0-10Vdc in to 4-20mA out Reversed Output Signal / Sensor Range adjustment</p>
---	--	---

Type	Supply ± 10%	Input Adjustable	Output Adjustable	Ambient Humidity	Ambient Temp °C	Mounting	Protection
ARM	24VAC/DC	0 - 44 mA 0 - 35 vdc	1 - 44 mA 0.25 - 20 vdc	10 to 95% non-condensing	0-50	Panel	IP00

DIMENSIONS:

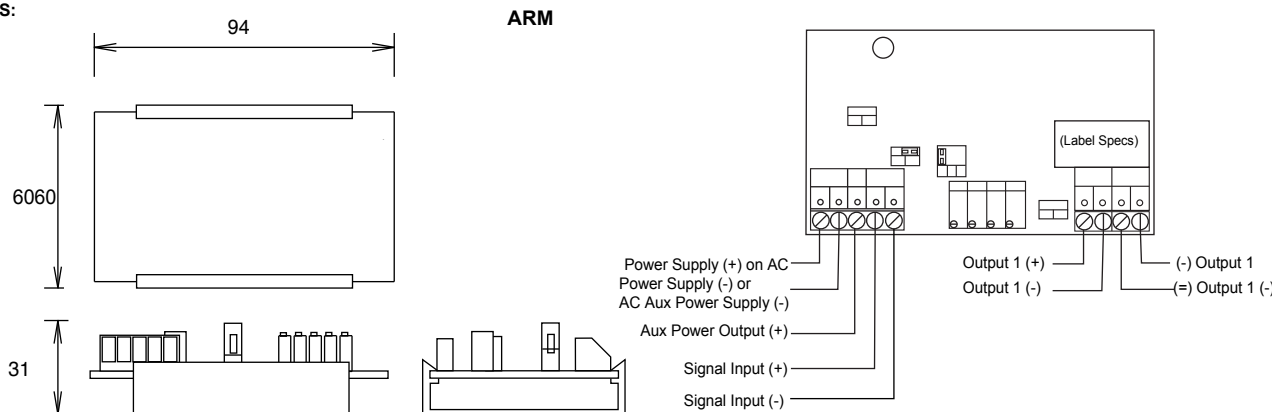

SETUP :

Factory Calibration -

No Attenuation of the Input Signal
Voltage Input
Voltage Output
Normal Acting Output Signal
No Offset to the Output Signal
Gain of 1 to the Output Signal (1:1)

Trim Pots Fully Clockwise

FINE
GAIN = gain of 1
REV = 0 volts reverse
OFFSET = 0 volts offset

Trim Pots Fully Counter-clockwise

ATTN = no input signal attenuation

The input signal is NOT isolated from the output.
When using a 24VAC supply, all devices connected to the ARM must use the same ground.
Terminals 0.5-2.5mm .
Min cable size 7/0.2mm. Max length 100m
Keep sensor/control signal wires away from power cables/units which may cause interference.
Screened cable is recommended

0-10Vdc to 5-10VDC

J1 to normal position.
J2 to positive position.
J3 to voltage input, voltage output.
Apply 0vdc to the input.
Adjust OFFSET for a 5vdc output.
Apply 10Vdc to the input.
Adjust ATTN for a 10vdc output.

0-10VDC to 4-20mA

J1 to normal position.
J2 to positive position.
J3 to voltage input, current output.
Apply 0vdc to the input.
Adjust OFFSET for a 4mA output.
Apply 10vdc to the input.
Adjust ATTN for a 20mA output.

4-20mA to 0-10VDC

J1 to normal position.
J2 to negative position.
J3 to current input, voltage output.
Apply 4mA to the input.
Adjust OFFSET for a 0vdc output.
Apply 20mA to the input.
Adjust GAIN for a 10vdc output.

0-10VDC to 8-2VDC

J1 to reverse position.
J2 to no offset position.
J3 to voltage input, voltage output.
Apply 0vdc to the input.
Adjust REV for an 8vdc output .
Apply 10vdc to the input.
Adjust ATTN for a 2vdc output.

0-10VDC to 0-5VDC

J1 to normal position.
J2 to no offset position.
J3 to voltage input, voltage output.
Apply 0vdc to the input.
Check output is 0vdc.
Apply 10vdc to the input.
Adjust ATTN for a 5vdc output.

Jumper Settings -

J1 - Output Direction

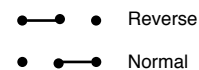

J2 - Offset Setting

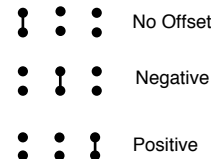

J3 - Input / Output Setting

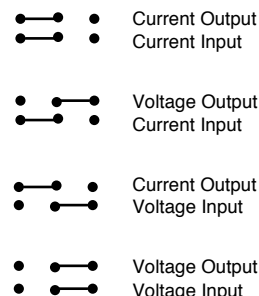

NOTE : Equivalent Calibration voltage = Required Input Signal Amps x 250 (ie. 4mA is 0.004 x 250 =1vdc and 20mA is 0.020 x 250 =5vdc)
Set up the unit with a voltage input and / or output (changing J3) using the formula. If required change J3 back to the correct setting.