

**ELECTRONIC THERMOSTATS
6-8 STAGES**

ETE..

These products monitor the temperature of air/liquid & control multiple heating/cooling or other units in various combinations in response to high or low temperatures. The set-point is adjustable via the dial on the pcb.
All units can be used with a range of remote accessories. The time delay prevents nuisance switching.

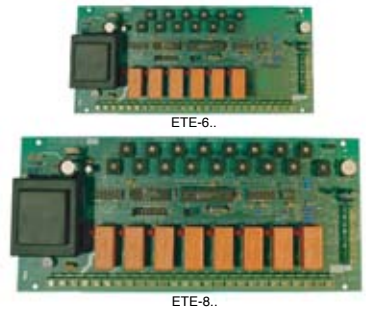

ALL SUPPLIED AS PCB ONLY FOR DIN RAIL HOLDER OR ENCLOSURES - SEE BELOW
*Protection with enclosure IP65
Supply 230VAC 50/60Hz
Volt free contacts
LED indication
Terminals 0.5-2.5mm
Enclosure Flammability = UL94-V2

Type	Stages	Range °C	Diff per Stage °C	Diff. between Stages °C	Supply ± 10%	230VAC SPD	Time Delay	Power Consumption	Protection*
ETE-650	6	-10/+50	0.5/3 adj.	0.5/3 adj.	230VAC	6 x 10(3)A	1-200s	<9VA	IP00*
ETE-695	6	25/95	0.5/3 adj.	0.5/3 adj.	230VAC	6 x 10(3)A	1-200s	<9VA	IP00*
ETE-850	8	-10/+50	0.5/3 adj.	0.5/3 adj.	230VAC	8 x 10(3)A	1-200s	<9VA	IP00*
ETE-895	8	25/95	0.5/3 adj.	0.5/3 adj.	230VAC	8 x 10(3)A	1-200s	<9VA	IP00*

OPTIONAL L24 = 24VAC supply N = Night Setting adj. 0-40 C on ETE-650/850 only. Via time switch (not supplied)

FOR USE WITH E10.. RANGE OF SENSORS, REMOTE ADJUSTERS & DISPLAYS - SEE SEPARATE DATA SHEET

DIMENSIONS: PCB ONLY 108H X 240W X 39D Mounting Centres 100H x 215W
WITH IP65 ENCLOSURE 175H X 250W X 75D WITH DIN RAIL HOLDER 118H X 246W X 69D

ACCESSORIES: **EE-M5T** Enclosure for ETE-6.. / ETE-8.. Protection IP65 ENCLOSURES SUPPLIED WITH TRANSPARENT LID



EE-M5T



EE-DR5

EE-DR5 Din Rail Holder for ETE-6.. / ETE-8..

WIRING:

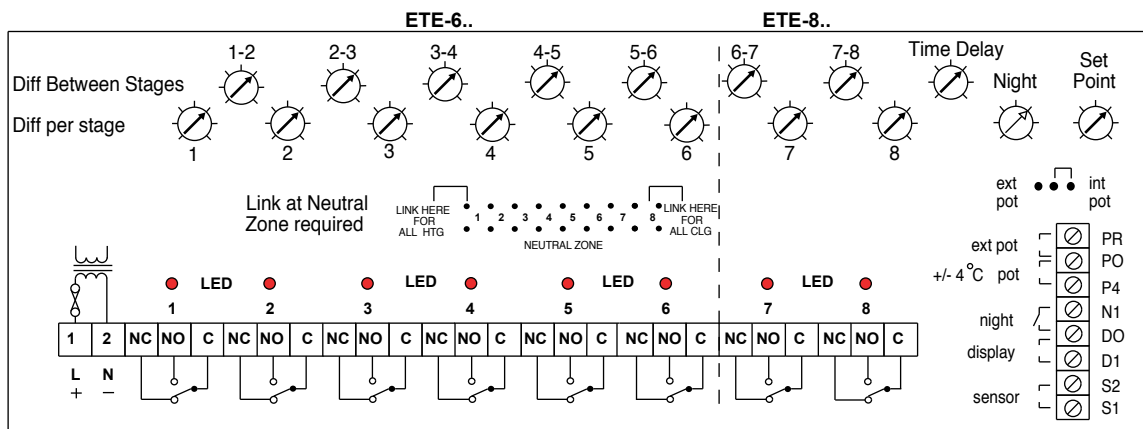

Override - Sensor terminals open : HTG : contacts C-NO close C-NC open CLG : contacts C-NC close C-NO open
Override - Sensor terminals linked : HTG : contacts C-NC close C-NO open CLG : contacts C-NO close C-NC open

HTG ONLY : Fit link to ALL HTG Wire C-NO Start from stage 1 and follow upwards in sequence.
CLG ONLY : Fit link to ALL CLG Wire C-NO Start from stage 1 and follow upwards in sequence.
HTG & CLG: Fit link to required neutral zone Wire C-NO From neutral zone wire CLG to lower stages (downwards) & HTG to higher stages (upwards).
ie 6 stage with 4 htg & 2 clg stages. Fit link between 2-3. Wire heating to stages 3,4,5,6 and cooling stages to 2 & 1. Heating will start from stage 3 and cooling will start from stage 2.

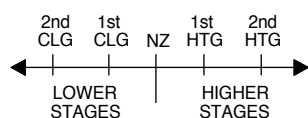

Neutral Zone : Set via diff. between HTG/CLG stages. When power is switched on, the unit starts from the neutral zone.
Time Delay : Allows setting of a fixed time period between each stage switching on or off.
OPTIONAL : Night setting - This is enabled upon contact closure on terminals N1 - D0

INT POT : Fit link here when using the setpoint dial on the pcb or the remote ±4 C adjuster.
EXT POT: Fit link here when using a front panel mounting full range set-point adjuster.

INSTALLATION: Min sensor cable size 7/0.2mm Max length 100m. Screened cable is recommended. Keep away from power cables/units which may cause interference. The screen should be earthed at the controller end only.